

## FITTING INSTRUCTION

Clamp mark in acc. with		Cables joining
ISO	PN	
1	L	Left directional lights
2	+	Rear fog lights
3	31	Ground
4	R	Right directional lights
5	58R	Right side parking lights
6	54	Stoplights
7	58L	Left side parking lights

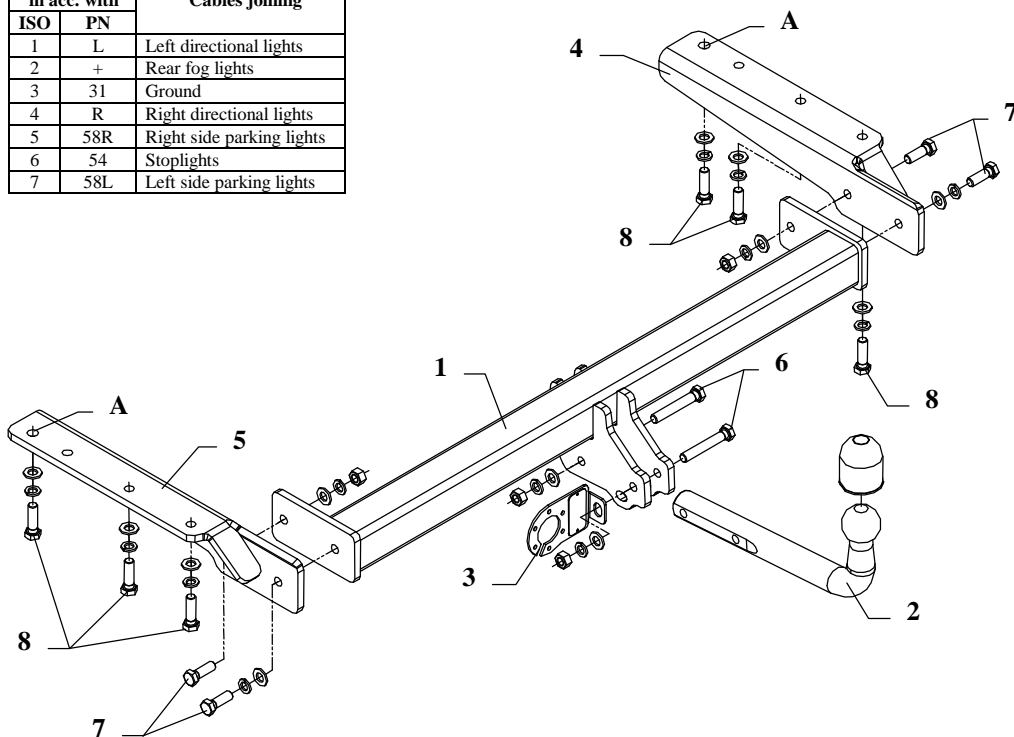

This towing hitch is designed to assembly in following cars:  
**TOYOTA LANDCRUISER J90/J95, 5 door**, produced since 1996 till 12.2002, catalogue no. **O46** and is prepared to tow trailers max total weight **3500 kg** and max vertical load **140 kg**.

### *From manufacturer*

Thank you for buying our product. Their reliability has been confirmed in many tests. Reliability of towing hitch depends also on correct assembly and right operation. For this reasons we kindly ask to read carefully this instruction and apply to hints.

*The towing hitch should be install in points described by a car producer.*

## The instruction of the assembly

1. Disassemble factory-made towing eye (will not be assembled again).
2. Disassemble the back muffler from the back handle.
3. Unscrew the cover of the petrol tank (only for one bolt from left and right side).
4. Fix brackets (pos. 4 and 5) to left and right chassis member using bolts M12x1.25x40mm (pos. 8) – through holes (pos. A) fix brackets together with cover of the tank.
5. Between brackets (pos. 4 and 5) slip the main bar of the towing hitch (pos. 1) and fix using bolts M12x35mm (pos. 7).
6. Fix tow-ball (pos. 2) with socket plate (pos. 3) using bolts M12x75mm (pos. 6) from accessories.
7. Tighten all bolts according to the torque shown in the table.
8. Connect electric wires of 7-poles socket according to the instruction of the car. (Recommend to make at authorized service station).
9. Complete paint layer damaged during installation.

Torque settings for nuts and bolts (8,8):	
<b>M 8</b> - 25 Nm	<b>M 10</b> - 55 Nm
<b>M 12</b> - 85 Nm	<b>M 14</b> - 135 Nm







## NOTE

After install the towing hitch you should get adequate note in registration book (at authorised service station).The car should be equipped with:

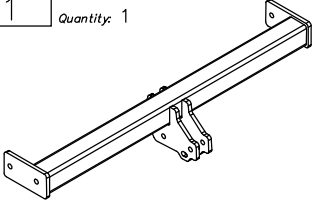
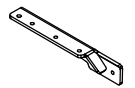
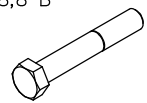
- Indicators
- Tow mirrors

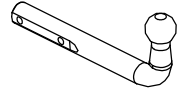
After 1000km of exploitation check all bolts and nuts. The ball of towing hitch must be always kept clear and conserve with a grease.

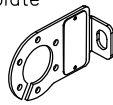
## Towing hitch accessories:

Pos. 1 Name: Main bar Quantity: 1	Pos. 4 Name: Right bracket Quantity: 1	Pos. 8 Name: Bolt 8,8 B Quantity: 6 Dim.: M12x1.25x40mm
	Pos. 5 Name: Left bracket Quantity: 1	Pos. 9 Name: Nut 8 B Quantity: 4 Dim.: M12
	Pos. 6 Name: Bolt 8,8 B Quantity: 2 Dim.: M12x75mm	Pos. 10 Name: Plain washer Quantity: 12 Dim.: Ø 13 mm
Pos. 2 Name: Tow ball Quantity: 1		
	Pos. 7 Name: Bolt 8,8 B Quantity: 4 Dim.: M12x35mm	Pos. 11 Name: Spring washer Quantity: 12 Dim.: Ø 12,2 mm
Pos. 3 Name: Socket plate Quantity: 1		
	Pos. 12 Name: Ball cover Quantity: 1	



**PPUH AUTO-HAK S.J.**

Produkcja Zaczepów Kulowych  
Henryk & Zbigniew Nejman  
76-200 SŁUPSK ul. Słoneczna 16K  
tel/fax (059) 8-414-414; 8-414-413  
E-mail: [office@autohak.com.pl](mailto:office@autohak.com.pl)  
[www.autohak.com.pl](http://www.autohak.com.pl)

## Towing hitch (without electrical set)

Class: **A50-X** Cat. no. **O46**

Designed for:

Manufacturer: **TOYOTA**

Model: **LANDCRUISER J90/J95**

Type: **5 doors**

produced since 1996 till 12.2002

Technical data:

**D-value: 14,7 kN**

maximum trailer weight: **3500 kg**

maximum vertical cup load: **140 kg**

**Approval number according to Directive 94/20/EC: e20\*94/20\*0455\*00**

### Foreword

This towing hitch is designed according to rules of safety traffic regulations. The towing hitch is a safety component and can be install only by qualified personnel. Any alteration or conversion of the towing hitch is prohibited and would lead to cancellation of design certification. Remove insulating compound and underseal from vehicle (if present) in the area of the matting surfaces of the towing hitch. The vehicle manufacturer's specifications regarding trailer load and max. vertical cup load are decisive for driving whereat values for the towing hitch cannot be exceeded.

*D-value formula:*

$$\frac{\text{Max trailer weight [kg]} \times \text{Max vehicle weight [kg]}}{\text{Max trailer weight [kg]} + \text{Max vehicle weight [kg]}} \times \frac{9,81}{1000} = D \text{ [kN]}$$